

# Tynemouth Software

## TYNEMOUTH DUAL 9 WAY D JOYSTICK FOR PET USERPORT

### OVERVIEW

When plugged into the userport of a Commodore PET / CBM / Mini PET, this will provide two 9 way D joystick ports. It conforms to a standard used by a number of games, and the Vice emulator.

It could also be used with VIC20, C64 and plus/4 machines, although it is not standard on those and the port numbers would be different.

### PARTS LIST

#### RESISTORS – ALL ¼W 5% OR BETTER (4 BAND RESISTOR COLOUR CODES SHOWN)

8 x 330Ω 

#### SEMICONDUCTORS

2 x 1N4148 signal diode

#### CONNECTORS / JUMPERS

1 x 24 way 0.156" (3.96mm) edge connector, with pins or solder tabs  
2 x 9 way D Male solder bucket connectors

### COMPONENT PLACEMENT

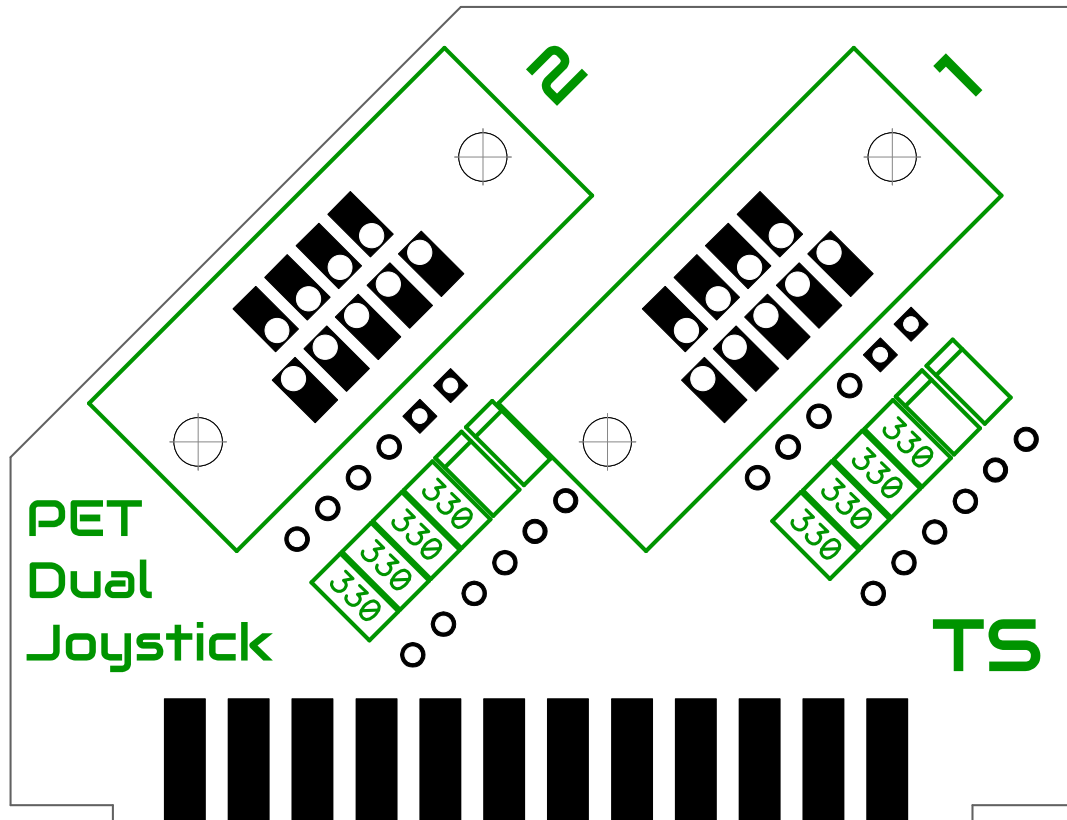

# Tynemouth Software

## SCHEMATIC

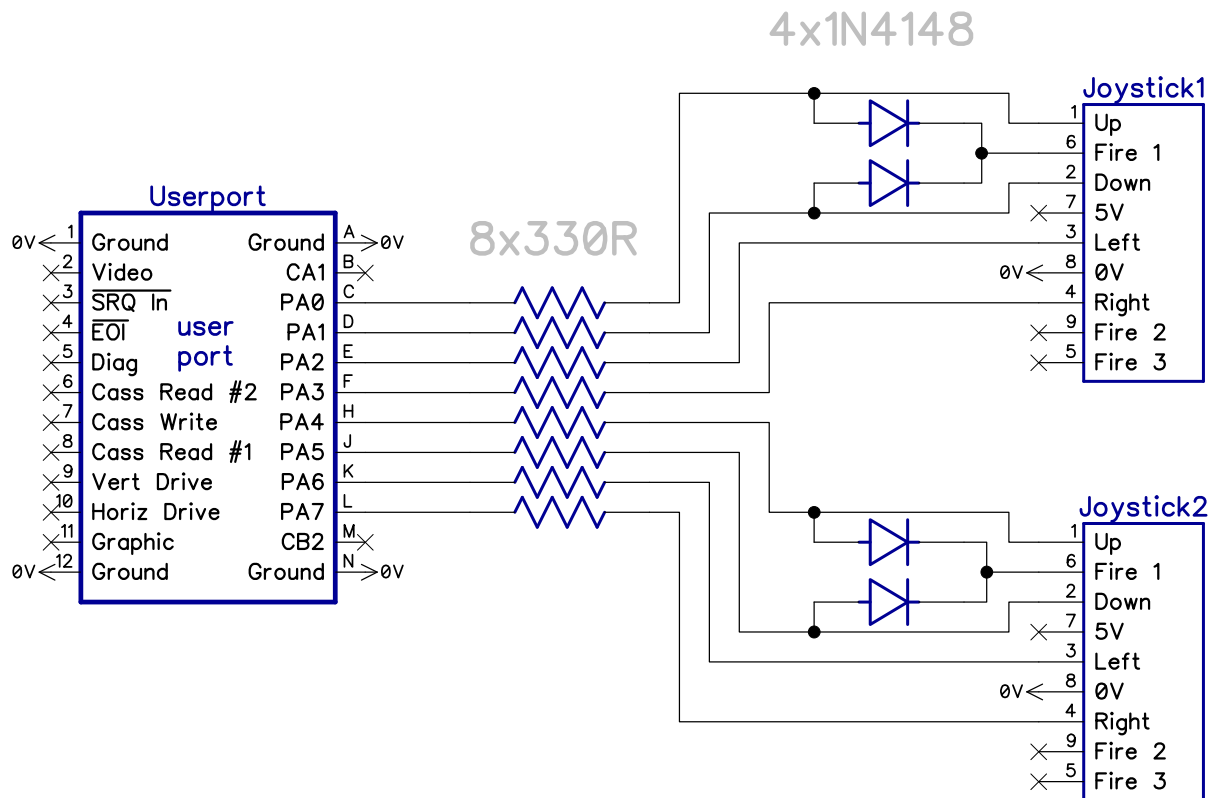

The four directions on each port are each connected to one of the port A inputs via a 330  $\Omega$  resistor. This protects the PET in case port A is set as an output.

The two fire signals are created by setting up and down at the same time, something which would not normally happen.

Userport port A is read at address 0xE841 (59457). All joystick signals are switched to 0V, so will pull that bit low. It is easiest to check the inverse, so test  $255 - \text{PEEK}(59457)$ . The values read are as follows, if both joysticks are in use, the value read will be the sum of both columns.

255 - PEEK(59457)	In Hex	Port 1	Port 2
0	0x00	-	-
1	0x01	Up	-
2	0x02	Down	-
3	0x03	Fire (Up + Down)	-
4	0x04	Left	-
8	0x08	Right	-
16	0x10	-	Up
32	0x20	-	Down
48	0x30	-	Fire (Up + Down)
64	0x40	-	Left
128	0x80	-	Right

# Tynemouth Software

## 9 WAY D JOYSTICK PORTS

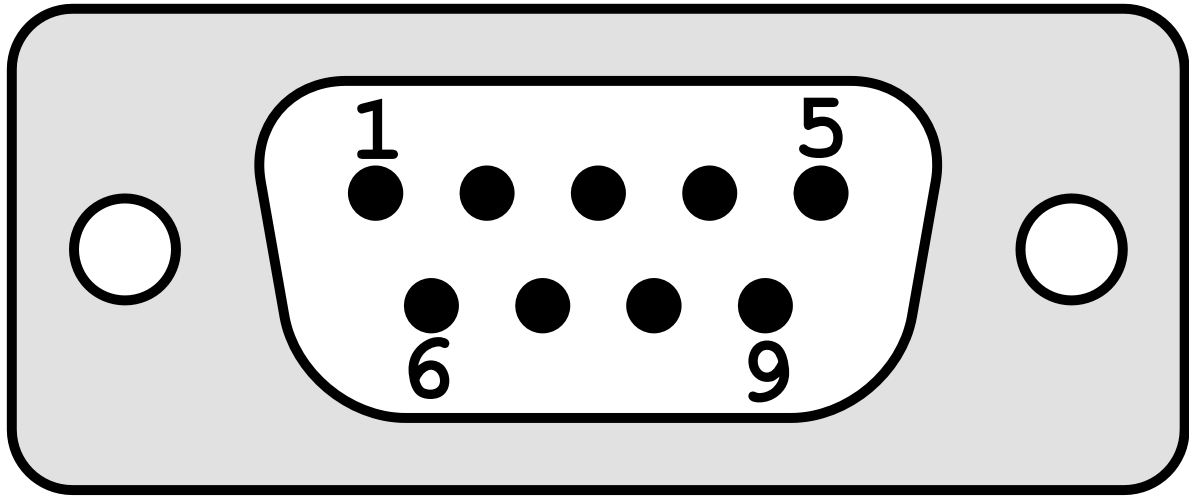

The joystick connector is the standard 9 way D pinout used on Atari and Commodore systems, Kempston interfaces etc. (note this is not the same as the Atari 5200, Spectrum +2 or Sega Genesis).

Pin	Signal
1	Up
2	Down
3	Left
4	Right
5	-
6	Fire
7	-
8	0V
9	-

The pins on the connectors are a tight fit in the PCB to give good mechanical connection. You may need to push down on the back of the PCB to get them fully in place.

There is no power on the PET userport, so no 5V is supplies to the joystick ports. This will prevent some autofire mechanisms from working.